



**Research Report of Mineral Processing  
Technology on Saudi Arabia Copper and  
Zinc Ore  
(supplement)**

**Beijing General Research Institute of Mining and Metallurgy**

**March 2009**

---

## CONTENTS

1	Review of the Au and Ag index .....	1
2	Examination of the tail of 2008-BGRIMM flowsheet locked cycle test .....	2
3	Grinding fineness test for Au and Ag roughing .....	4
4	CaO dosage (pH) test for copper roughing .....	6
5	Collector Species for Au and Ag Roughing.....	8
6	Fineness of regrinding for Cu Cleaning .....	9
7	Locked-cycle test of the recommended (2008-BGRIMM) flowsheet.....	11
8	Test on roughing flotation for samples of Saadah and Al Houra .....	13

## Research Report of Mineral Processing Technology on Saudi Arabia Copper and Zinc Ore (supplement)

On February 12, 2009 the report meeting about “Research Report of Mineral Processing Technology on Saudi Arabia Copper and Zinc Ore” was held in BGRIMM, and a proposal of additional testwork to increase the recovery of Au and Ag in copper concentrate was put forward. The results of this test work are presented as follows:

### 1 Review of the Au and Ag index

The head analyses for 2008-BGRIMM is shown in Tab.1 and The head analyses for 1994-Lakefield is shown in Tab.2.

**Tab. 1 The head analyses for 2008-BGRIMM**

Sample	grade			
	Cu%	Zn%	Au g/t	Ag g/t
Saadah	1.31	4.67	0.93	31.68
Al Houra	0.84	3.90	0.65	25.90
Overall	1.21	4.34	0.90	30.10

**Tab. 2 The head analyses for 1994-Lakefield**

Sample	grade			
	Cu%	Zn%	Au g/t	Ag g/t
Saadah	1.15	5.43	0.68	24.3
Al Houra	1.29	5.79	2.13	71.5
Moyeath	0.91	8.93	1.67	75.7
Overall	1.13	6.07	1.30	47.6

Tab.1 shows the overall composite of 2008-BGRIMM testwork was made up of two samples from Saadah and Al Houra, and Tab.2 shows the overall composite of 1994-Lakefield testwork was made up of three samples from Saadah, Al Houra and Moyeath. There are significant difference between this two ore samples, especially analyses of 1994-Lakefield sample from Al Houra with its almost highest grade of the four metal element.

The Au and Ag grades of 2008-BGRIMM samples are lower than that of 1994-Lakefield samples by 0.40g/t and 17.5g/t respectively.

The results of 2008-BGRIMM test are shown in Tab.3 and those of 1994-Lakefield in

Tab.4.

**Tab. 3 The results of 2008-BGRIMM test**

Product	Yield, %	Assay				Recovery, %			
		Cu%	Zn%	Au g/t	Ag g/t	Cu	Zn	Au	Ag
Talc Conc.	14.46	0.17	0.81	0.45	14.33	2.11	2.63	7.26	6.89
Cu Conc.	3.98	26.44	5.58	4.73	212.18	87.83	4.97	21.00	28.07
Zn Conc.	7.04	0.50	54.10	2.36	87.82	2.91	85.23	18.54	20.55
Tail	74.52	0.115	0.43	0.64	17.97	7.15	7.17	53.20	44.49
Feed	100.00	1.20	4.47	0.90	30.09	100.00	100.00	100.00	100.00

**Tab.4 The results of 1994-Lakefield test**

Product	Assay				Recovery, %			
	Cu%	Zn%	Au g/t	Ag g/t	Cu	Zn	Au	Ag
Cu Conc.	25.0	7.63	15.50	511	85.0	5.0	47.8	41.8
Zn Conc.	0.66	51.40	1.83	155	5.5	83.6	13.9	23.2
Tail	0.13	0.79	0.57	19.4	9.5	11.4	38.4	34.9
Feed	1.16	5.59	1.27	48.5	100.0	100.0	100.0	100.0

The Au and Ag grades of the copper concentrate of 2008-BGRIMM test are lower than those of 1994-Lakefield test by 9.92g/t and 298.82g/t respectively, while the Au and Ag recoveries are lower by 26.8 percent points and 13.1 percent points respectively.

## 2 Examination of the tail of 2008-BGRIMM flowsheet locked cycle test

Loss of Ag: The amount of Ag (freibergite and hessite etc.) which could be cyanide-leached was measured by selective dissolution method, and the result is given in Table 5.

**Table 5 The analysis result of Ag minerals which could be cyanide-leached in flotation tail**

Exposed Individual Ag Mineral		Ag Carried with Other Minerals		Total	
Content, g/t	Occupancy, %	Content, g/t	Occupancy, %	Content, g/t	Occupancy, %
14.00	70.42	5.88	29.58	19.88	100.00

“Ag carried with other minerals” includes Ag carried in pyrite and gangue, analysis result shows that pure pyrite contains 9.40g/t Ag, and calculated according to pyrite content (50%) in the raw ore, its Ag-carrying is up to about 4.7g/t, Ag carried in gangue is only (5.88-4.7)=1.18

(g/t). So, the recovery of independent Ag minerals is poor.

Loss of Au: it is difficult to observe the loss of Au by microscope, so only by the method of selective dissolution could Au distribution in important phases be found out.

There are already very few Cu, Zn sulphides in the tail, and the main minerals are gangue and pyrite; besides, extreme few Ag telluride is seen lost as fine granules. Overall, it is suitable to classify the loss of Au into 2 states for quantitative analysis. The method used is: Au leached with cyanide from tail directly is expressed as fine monomers or exposed Au intergrowths; the Au contained in leaching residue is almost Au in pyrite and gangue. The result is shown in Table 6.

**Table 6 The analysis result of Au carried with minerals in flotation tail**

Exposed Individual Au Mineral		Au Carried with Other Minerals		Total	
Content, g/t	Occupancy, %	Content, g/t	Content, g/t	Occupancy, %	Content, g/t
0.33	54.10	0.28	45.90	0.61	100

According to the analysis result, pyrite with fine grinding extracted from tail contains 0.55g/t Au, but the relative content of pyrite in tail is about 50%, and calculated according to it, “Au carried with other minerals” of tail is actually Au carried by pyrite. Au which can be leached with cyanide accounts about for 55%. Although individual Au minerals are not observed, it can be seen a closely associated relation between Au and Ag minerals from previous description for the intergrowth structure of Ag mineral.

It can be seen from the Tab.5 and Tab.6 that further primary grind will increase the separation of Au and Ag minerals and benefic to the recovery of Au and Ag in Cu concentrate, meanwhile to increase suitably the content of pyrite containing Au and Ag in Cu concentrate will increase the recovery Au and Ag in Cu concentrate, therefore in order to increase the recovery Au and Ag in Cu concentrate, the testwork was carried out on grinding fineness for Cu rougher flotation, Au- and Ag-specific collectors and reducing the dosage of pyrite depressor CaO.

In order to have a view on the differences in flotation performance between the Sadaah and Al Houra samples, teskwork on roughing flotation of samples of Saadah and Al Houra was done respectively.

### 3 Grinding fineness test for Au and Ag roughing

The flowsheet of grinding fineness test for Au and Ag roughing is shown in Figure 1, the result is presented in table 7.

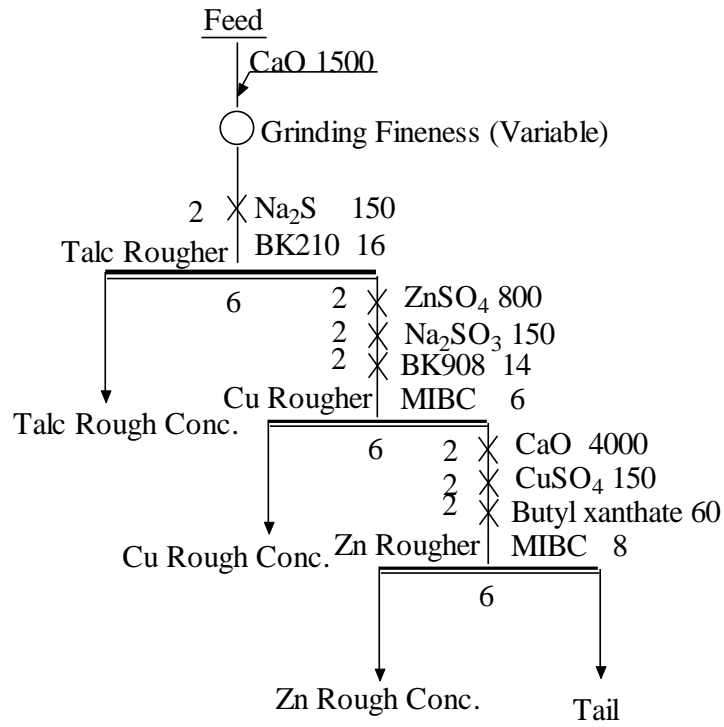

Figure 1 The flowsheet of grinding fineness test for Au and Ag roughing

**Table 7 The result of grinding fineness test for Au and Ag roughing**

Grinding Fineness, % -0.074mm -0.043mm	Product	Yield, %	Assay				Recovery, %			
			Cu, %	Zn, %	Au,g/t	Ag,g/t	Cu	Zn	Au	Ag
91.9 77.2	Talc Rough Conc.	12.89	0.29	1.09	0.32	12.93	3.25	3.16	4.57	5.51
	Cu Rough Conc.	11.79	7.83	5.54	2.23	72.12	80.21	14.66	29.08	28.08
	Zn Rough Conc.	12.23	0.73	27.76	1.91	76.55	7.76	76.23	25.85	30.92
	Tail	63.09	0.16	0.42	0.58	17.03	8.78	5.95	40.50	35.49
	Feed	100.00	1.15	4.45	0.90	30.27	100.00	100.00	100.00	100.00
93.1 82.8	Talc Rough Conc.	11.15	0.29	1.08	0.32	13.25	2.77	2.72	4.14	4.79
	Cu Rough Conc.	13.51	7.01	4.16	1.85	51.81	80.99	12.71	28.97	22.68
	Zn Rough Conc.	12.20	0.78	28.31	1.83	89.72	8.14	78.14	25.89	35.48
	Tail	63.14	0.15	0.45	0.56	18.11	8.10	6.43	41.00	37.05
	Feed	100.00	1.17	4.42	0.86	30.86	100.00	100.00	100.00	100.00
94.8 89.7	Talc Rough Conc.	12.38	0.27	0.99	0.41	12.33	2.84	2.62	5.79	4.79
	Cu Rough Conc.	12.06	7.86	3.46	2.21	60.49	80.60	8.93	30.42	22.88
	Zn Rough Conc.	11.85	0.89	32.46	1.81	94.69	8.97	82.32	24.49	35.21
	Tail	63.71	0.14	0.45	0.54	18.56	7.59	6.13	39.29	37.12
	Feed	100.00	1.18	4.67	0.88	31.86	100.00	100.00	100.00	100.00
97.1 93.2	Talc Rough Conc.	11.55	0.34	1.27	0.32	12.93	3.43	3.18	4.13	4.71
	Cu Rough Conc.	14.49	6.35	4.22	2.01	72.12	80.24	13.25	32.54	32.91
	Zn Rough Conc.	12.11	0.78	29.45	1.87	76.55	8.24	77.27	25.31	29.20
	Tail	61.85	0.15	0.47	0.55	17.03	8.09	6.30	38.02	33.18
	Feed	100.00	1.15	4.61	0.89	31.74	100.00	100.00	100.00	100.00

According to the result of Table 7, the primary grinding fineness of 94.8% -0.074mm (89.7% -0.043mm) is appropriate.

#### 4 CaO dosage (pH) test for copper roughing

The flowsheet of CaO dosage (pH) test for copper roughing is shown in Figure 2, and the result is given in Table 8.

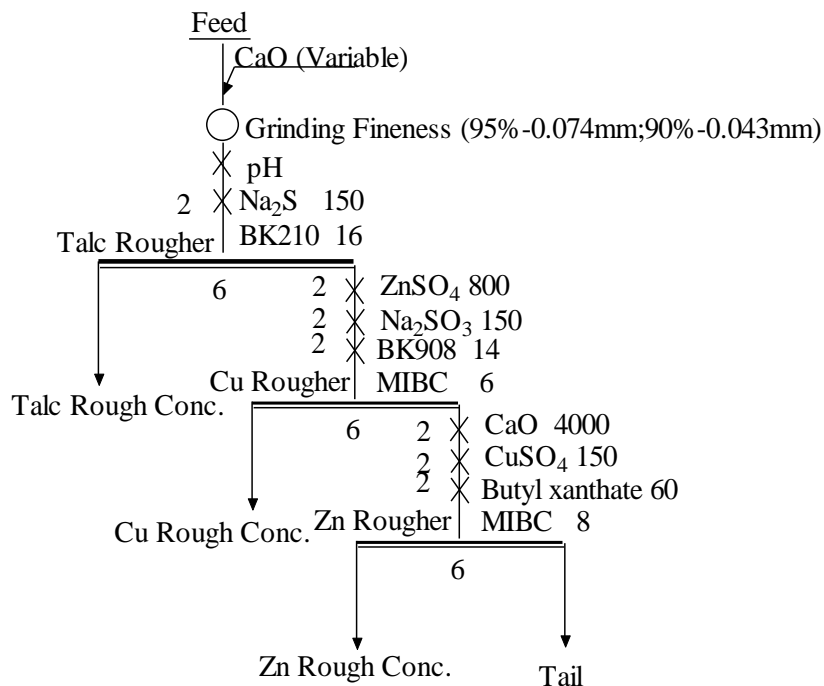

Figure 2 The flowsheet of CaO Dosage or pH for Au and Ag roughing



**Table8 The result of CaO Dosage or pH for Au and Ag roughing**

CaO Dosage or pH	Product	Yield, %	Assay				Recovery, %			
			Cu, %	Zn, %	Au,g/t	Ag,g/t	Cu	Zn	Au	Ag
0 7.8	Talc Rough Conc.	13.56	0.42	1.71	0.31	13.85	4.83	5.18	5.22	6.51
	Cu Rough Conc.	22.81	4.34	4.44	1.65	60.68	83.91	22.67	46.71	48.00
	Zn Rough Conc.	15.43	0.33	19.55	0.98	37.86	4.32	67.51	18.76	20.26
	Tail	48.20	0.17	0.43	0.49	15.09	6.94	4.64	29.31	25.23
	Feed	100.00	1.18	4.47	0.81	28.83	100.00	100.00	100.00	100.00
400 8.6	Talc Rough Conc.	12.84	0.47	1.80	0.41	18.09	5.11	4.89	6.19	7.80
	Cu Rough Conc.	18.36	5.18	4.76	2.10	70.02	80.58	18.48	45.36	43.20
	Zn Rough Conc.	15.85	0.43	21.38	0.96	41.27	5.78	71.71	17.92	22.01
	Tail	52.95	0.19	0.44	0.49	15.17	8.53	4.92	30.53	26.99
	Feed	100.00	1.18	4.73	0.85	29.75	100.00	100.00	100.00	100.00
800 8.9	Talc Rough Conc.	11.39	0.41	1.72	0.35	21.13	3.91	4.26	4.57	7.89
	Cu Rough Conc.	17.82	5.43	4.83	2.12	74.21	81.03	18.72	43.31	43.38
	Zn Rough Conc.	15.35	0.45	21.41	1.12	40.98	5.78	71.46	19.70	20.63
	Tail	55.44	0.20	0.46	0.51	15.45	9.28	5.55	32.42	28.10
	Feed	100.00	1.19	4.60	0.87	30.49	100.00	100.00	100.00	100.00
1600 9.5	Talc Rough Conc.	11.40	0.35	1.90	0.45	21.18	3.44	4.74	5.79	8.07
	Cu Rough Conc.	16.06	5.76	5.23	2.26	77.82	79.66	18.36	40.97	41.78
	Zn Rough Conc.	12.95	0.55	25.13	1.02	42.03	6.13	71.17	14.91	18.20
	Tail	59.59	0.21	0.44	0.57	16.04	10.77	5.73	38.33	31.95
	Feed	100.00	1.16	4.57	0.89	29.92	100.00	100.00	100.00	100.00

From above result, a CaO-dosage of 400g/t (pH8.6) could be chosen.

## 5 Collector Species for Au and Ag Roughing

The flowsheet of collector species test for Au and Ag roughing is shown in Figure1, the result is presented in table 9.

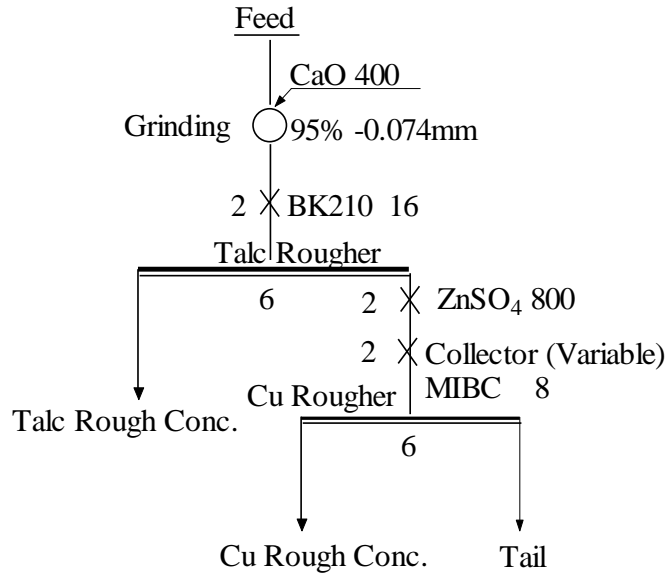

Figure 3 The flowsheet of grinding fineness test for Au and Ag roughing

**Table 9 The result of collector species test for Au and Ag roughing**

Collector species	Product	Yield, %	Assay				Recovery, %			
			Cu, %	Zn, %	Au,g/t	Ag,g/t	Cu	Zn	Au	Ag
BK301	Talc Rough Conc.	14.11	0.33	1.12	0.23	13.27	3.89	3.47	3.77	6.33
	Cu Rough Conc.	14.32	6.74	4.48	2.38	78.24	80.58	14.08	39.63	37.86
	Tail	71.57	0.26	5.25	0.68	23.08	15.54	82.45	56.59	55.82
	Feed	100.00	1.20	4.56	0.86	29.59	100.00	100.00	100.00	100.00
BK908	Talc Rough Conc.	13.81	0.32	1.27	0.31	14.55	3.69	3.82	4.87	6.73
	Cu Rough Conc.	14.41	6.80	4.18	2.41	78.03	81.91	13.12	39.54	37.67
	Tail	71.78	0.24	5.31	0.68	23.12	14.40	83.05	55.58	55.60
	Feed	100.00	1.20	4.59	0.88	29.85	100.00	100.00	100.00	100.00
BK908B	Talc Rough Conc.	13.92	0.33	1.13	0.31	14.11	3.83	3.43	4.95	6.78
	Cu Rough Conc.	14.02	7.04	3.88	2.78	84.67	82.34	11.84	44.67	40.98
	Tail	72.06	0.23	5.40	0.61	21.00	13.83	84.73	50.38	52.24
	Feed	100.00	1.20	4.59	0.87	28.97	100.00	100.00	100.00	100.00
9538	Talc Rough Conc.	13.77	0.37	1.37	0.26	13.80	4.40	4.09	4.20	6.68
	Cu Rough Conc.	10.32	8.14	3.78	3.28	91.20	72.63	8.46	39.70	33.08
	Tail	75.91	0.35	5.31	0.63	22.58	22.97	87.44	56.10	60.24
	Feed	100.00	1.16	4.61	0.85	28.45	100.00	100.00	100.00	100.00

The result indicates that when BK908B is used as the collector for Cu rougher, the assay and recovery of Cu/Au/Ag rougher concentrate were 7.04%, 2.78g/t, 84.67g/t and 82.34% , 44.67%, 40.98% respectively. So in order to increase the recovery of Au and Ag in Cu concentrate BK908 B could be used as collector for Cu rougher.

## 6 Fineness of regrinding for Cu Cleaning

Cu cleaning condition test was carried out with Cu rough concentrate used as feed. The flowsheet of regrinding fineness test for Cu cleaning is shown in Figure 4, and the result is presented in Table 10.

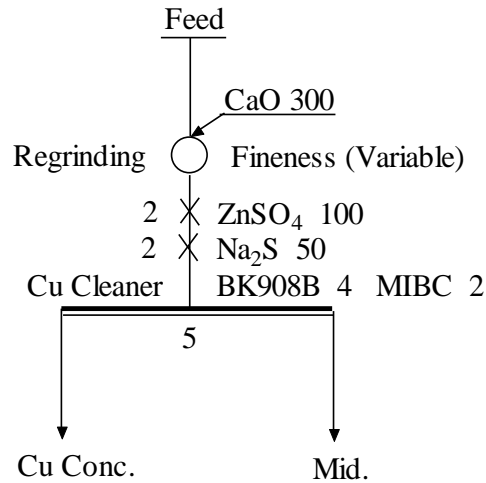

**Fig.4** The flowsheet of regrinding fineness test for Cu cleaning

**Tab. 10** The result of regrinding fineness test for Cu cleaning

Regrinding Fineness, % -0.038mm	Product	Yield, %	Assay				Recovery, %			
			Cu, %	Zn, %	Au, g/t	Ag, g/t	Cu	Zn	Au	Ag
No Regrinding 54.8	Cu Conc.	73.10	8.22	4.33	2.15	69.32	96.79	79.53	80.67	78.57
	Mid.	26.90	0.74	3.03	1.40	51.39	3.21	20.47	19.33	21.43
	Feed	100.00	6.21	3.98	1.95	64.50	100.00	100.00	100.00	100.00
66.6	Cu Conc.	66.46	8.61	3.85	2.31	72.29	90.55	60.94	74.95	72.32
	Mid.	33.54	1.78	4.89	1.53	54.83	9.45	39.06	25.05	27.68
	Feed	100.00	6.32	4.20	2.05	66.43	100.00	100.00	100.00	100.00
85.5	Cu Conc.	51.73	11.22	3.10	2.64	78.79	91.34	38.57	67.53	62.91
	Mid.	48.27	1.14	5.29	1.36	49.78	8.66	61.43	32.47	37.09
	Feed	100.00	6.35	4.16	2.02	64.79	100.00	100.00	100.00	100.00
89.7	Cu Conc.	51.73	10.93	3.07	2.42	82.44	88.78	38.84	65.60	63.90
	Mid.	48.27	1.48	5.18	1.36	49.91	11.22	61.16	34.40	36.10
	Feed	100.00	6.37	4.09	1.91	66.74	100.00	100.00	100.00	100.00

It is proved from Table 10 that flotation effect of Cu rough concentrate with regrinding is better than that without regrinding for Cu/Zn separation flotation. So in this testwork a regrinding fineness of 86% -0.038mm is appropriate.

## **7 Locked-cycle test of the recommended (2008-BGRIMM) flowsheet**

According to the recommended (2008-BGRIMM) flowsheet structure and above results of condition tests, a locked-cycle test of the flowsheet to increase Au and Ag recovery in Cu concentrate was carried out. The test flowsheet is shown in Fig.5, and the test result is presented in Tab.11.

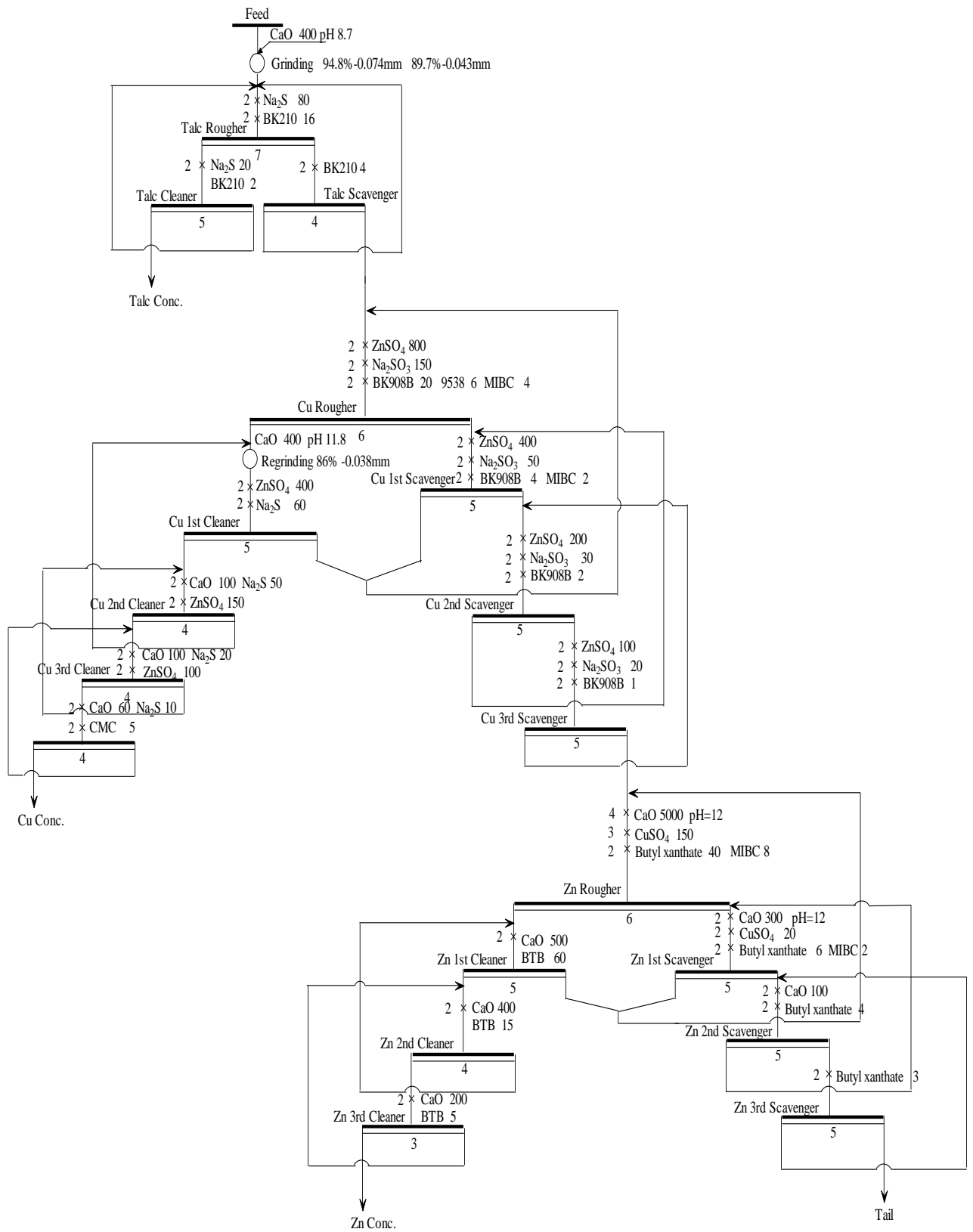

**Fig.5 The flowsheet of locked-cycle test**

**Tab.11 The result of locked-cycle test**

Product	Yield, %	Assay, %				Recovery, %			
		Cu	Zn	Au , g/t	Ag , g/t	Cu	Zn	Au	Ag
Talc Conc.	13.73	0.14	0.82	0.38	13.98	1.60	2.43	6.06	6.39
Cu Conc.	4.77	22.42	4.78	5.17	238.75	89.06	4.92	28.63	37.94
Zn Conc.	7.29	0.52	54.69	2.12	89.26	3.16	85.94	17.94	21.67
Tail	74.21	0.10	0.42	0.55	13.75	6.18	6.72	47.38	33.99
Feed	100.00	1.20	4.64	0.86	30.02	100.00	100.00	100.00	100.00

The result of locked-cycle test is:

Cu Conc.: Cu assay is 22.42% with the recovery of 89.06%, and contains Au 5.17g/t with its recovery of 28.63%, and contains Ag 238.75g/t with its recovery of 37.94%.

### 8 Test on roughing flotation for samples of Saadah and Al Houra

In order to have a view on the differences in flotation performance between the Sadaah and Al Houra samples, tests of roughing flotation was carried on samples from Saadah and Al Houra respectively. The test-flowsheet is shown in Fig.7, the results are presented in tab. 12.

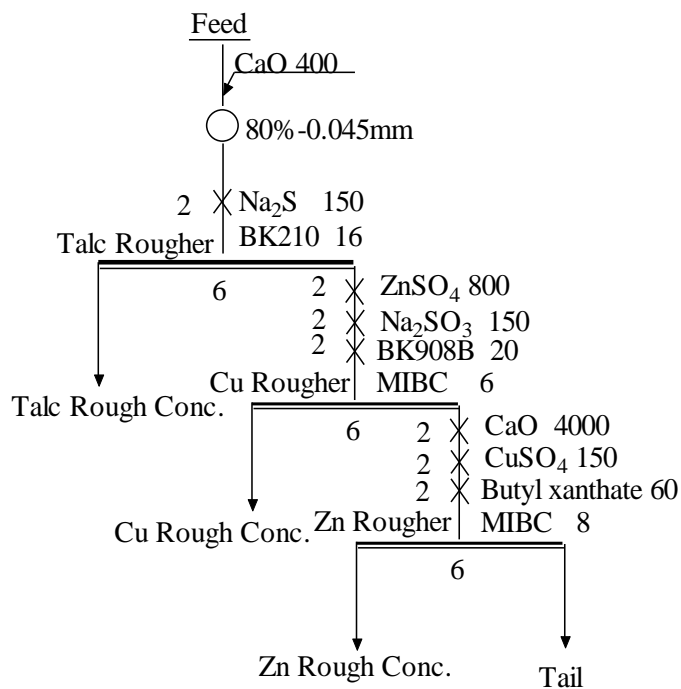

**Fig.7 The flowsheet of roughing for Saadah and Al Houra samples**

**Tab.7 The result of roughing for Saadah and Al Houra samples**

Sample	Product	Yield, %	Assay				Recovery, %			
			Cu, %	Zn, %	Au,g/t	Ag,g/t	Cu	Zn	Au	Ag
<b>Al Houra</b>	Talc Rough Conc.	22.01	0.21	1.10	0.21	12.11	5.66	6.22	7.21	9.81
	Cu Rough Conc.	26.06	2.54	3.24	1.05	43.66	81.03	21.70	42.69	41.85
	Zn Rough Conc.	11.45	0.49	23.26	1.32	61.11	6.87	68.43	23.57	25.73
	Tail	40.48	0.13	0.35	0.42	15.18	6.44	3.65	26.53	22.61
	Feed	100.00	0.82	3.89	0.64	27.18	100.00	100.00	100.00	100.00
<b>Saadah</b>	Talc Rough Conc.	12.50	0.18	1.11	0.31	11.87	1.70	2.82	4.07	4.92
	Cu Rough Conc.	26.35	4.22	3.25	1.72	53.87	84.26	17.43	47.61	47.11
	Zn Rough Conc.	14.20	0.71	26.20	1.52	48.51	7.64	75.73	22.67	22.86
	Tail	46.95	0.18	0.42	0.52	16.12	6.40	4.02	25.65	25.11
	Feed	100.00	1.32	4.91	0.95	30.14	100.00	100.00	100.00	100.00

Compared in Tab.7 are open-circuit batch test results. It can be seen that a better result of was achieved for the Sadaah composite sample with lower talc content (yield of talc rough Conc. is 12.5% for the Sadaah sample and 22.01% for the Al Houra sample).



**President of BGRIMM:** Jiang Kaixi

**Vice President in charge:** Zhan Kai

**Dean of Sub-institute for Mineral Projects:** Wang Fuliang

**Chief technical reviewer:** Wang Zhongming

**Principle of project:** Wang Rongsheng Li Chongde

**Main test personnel:** Lu Shuoshi; Li Chongde;  
Zhou Bingzi; Chen Jinghua;  
Wang Rongsheng  
etc.

**Main examination personnel:** Yu Li; Wang Hongxia; Tang Shufang;  
Rong Huixuan; Yin Dongxia; etc.

**Report writing :** Li chongde; Wang Rongsheng